

Broadwater County Road Standards

1. Road Classification

The purpose of a functional classification system for county roads is to provide for the safe and efficient movement of people and goods while preserving residential areas and maintaining the economic vitality of commercial and industrial areas. The system classifies transportation facilities according to an appropriate integrated network. It is intended to link land use development activities with transportation facilities for optimum utilization of both. The County's functional classification system is intended to be in compliance with the Federal classification system.

Roadways within the county are classified as:

- 1.1 Local Road – 1-400 ADT.** Roadways used primarily for direct access to residential, commercial, industrial, or other abutting property. The average daily traffic (ADT) would be projected to be 1-400. If the roadway is located in a development with urban density, then paving could be required.
- 1.2 Local Road – 401-1500 ADT.** Roadways used primarily for direct access to residential, commercial, industrial, or other abutting property. The average daily traffic (ADT) would be projected to be 401-1500. All local roads with 401-1500ADT shall be paved.
- 1.3 Minor Collector.** Minor collector streets serve the dual functions of distributing traffic between local roads and arterials, and providing access to abutting properties. Therefore, higher traffic volumes and higher speeds are the norm. Minor collector streets would carry average daily traffic volumes of 1,500-3,500. Minor Collector streets connect arterial networks and also connect neighborhoods to commercial areas; fixed route transit service is low while bicycle and pedestrian activities range from moderate to high. All collector streets shall be paved.
- 1.4 Major Collector.** Major collector streets serve the dual functions of distributing traffic between local roads and arterials, and providing access to abutting properties. Therefore, higher traffic volumes and higher speeds are the norm. Major collector streets would carry average daily traffic volumes greater than 3,500. Major collector streets connect arterial networks and also connect neighborhoods to commercial areas; fixed route transit service is low while bicycle and pedestrian activities range from moderate to high. All collector streets shall be paved.
- 1.5 Arterial.** That part of the roadway system serving as the principal network for through traffic flow. The routes connect areas of principal traffic generation and important rural highways entering the city. Typically, a subdivision proposal does not require an arterial roadway. Therefore, no county-specific standards are included herein. If an arterial roadway standard is needed, the Montana Department of Transportation (MDT) standards for the appropriate roadway shall be used.

2. Design Controls & Criteria.

2.1 Standard Specifications.

2.1.1 The standards for Broadwater County roads and bridges, and all other construction within publicly owned right-of-way, shall consist of:

2.1.1.1 The Broadwater County Roadway Standards (County RS) which are the design criteria herein.

2.1.1.2 The Broadwater County Bridge Standards, approved January 1999.

2.1.1.3 The current published edition of the Montana Public Works Standard Specifications as published and distributed by the Montana Contractors Association.

2.1.1 Reference Standards: To implement the above standards, the following publications and their subsequent revisions shall apply:

2.1.2.1 The current version of the Montana Roadway Design Manual, published by the MDT.

2.1.2.2 The current version of the Standard Specifications for Road and Bridge Construction, published by the MDT.

2.1.2.3 The current version of the Policy of Geometric Design of Highway and Streets, published by the American Association of State Highway and Transportation Officials (AASHTO).

2.1.2.4 The current version of the Manual on Uniform Traffic Control Devices (MUTCD) published by the Federal Highway Administration.

2.1.2 In the event of conflict with any of the specifications, the County shall specify, in writing, which of the standard specifications will apply.

2.2 Plans for Construction of Roads and Utilities. The Design Engineer shall submit plans and specifications for street and utility construction for the proposed development to the County for review. The plans and specifications shall include a vicinity map, a plan and profile, special provisions, and reference to the standards specifications including typical sections.

2.2.1 The Plan. The 11" x 17" submittal plan shall include the road alignment at a scale of not less than 1" to 100' showing centerline stationing on all intersection streets, with bearing on centerlines, curve data on all horizontal curves; right-of-way; relevant topography; existing and proposed utility location; street names in the development and adjoining the development; typical roadway section showing placement of utilities, existing and proposed drainage and storm water features; sidewalk ramp locations; flood plain and wetland boundaries; signalization, channelization, striping and signing; and further data as may be required by the County

2.2.2 The Profile. The profile shall show the relevant original ground lines using the same stationing as in the plan, control elevations, grade line showing the proposed grades, vertical curves; all bench marks, the vertical datum, and such further information as may be reasonably required. For new streets, the relevant original ground lines will show the ground line at centerline at a minimum and also at the edges of the right-of-way if grade differences are significant (or alternatively surveyed contour lines on the plan view). For existing streets, the Design Engineer shall provide elevations at the edge of the existing pavement or face of curb, whichever is applicable. The profile lines for roads extending to the perimeter of any development shall be extended a minimum of three hundred (300') feet beyond the perimeter to include any change in contours which would affect the profile of the extension of the proposed road.

2.2.3 Special Provisions. Any special technical provisions shall be shown or referenced on the plans.

2.2.4 Format. The cover sheet of all plans shall include a statement identifying which standard specifications will apply to the project. Plan and profile may be shown on the same sheet with profiles shown on the bottom half of the sheet. Submitted sheets shall measure 11" x 17" based on being a true 1/2 size of a 24" x 36" drawing. The 24" x 36" original (not submitted) drawing shall have a borderline of 2 1/2" on the left side of the length of the sheet and 1/2" on remaining sides, so that the true 11" x 17" drawing is proportioned correctly. When more than two plan sheets are used, an overall development layout shall be submitted showing the relationship of roads and utilities.

2.2.4.1 A north arrow shall be shown on each plan view sheet and adjacent to any other drawing which is not oriented the same as other drawings on the sheet.

2.2.4.2 Letter size shall not be smaller than 0.12 of an inch high which equates to a 0.06 of an inch height for the submitted 11" x 17" drawing.

2.2.4.3 All detail drawings, including standard drawings, shall be included in the drawings unless the county standards are referenced with appropriate dimensions clearly supplied in the drawings.

2.2.5 A title block shall appear on each sheet of the plan set and shall be placed in the lower, right-hand corner of the sheet, across the bottom edge of the sheet or across the right-hand edge of the sheet. The title block shall include the name of the project, the engineering firm, the sheet title and the owner if not shown on the first sheet.

2.3 Design Criteria. The Broadwater County roadway design criteria are set out in Table A. Such criteria are applicable to roads located within and adjacent to a development. These criteria are intended for normal conditions. The County may require higher standards for unusual site conditions.

3. Typical Roadway Section.

The typical roadway section shall be as shown on the Typical Road Section in Figure 1, 2, 3 and 4 and shall be detailed on the construction plans submitted for each new roadway or improvement to an existing roadway.

The following sections contain information relative to descriptions of the roadway structural section elements.

- 3.1 Asphalt Seal Coat.** When asphalt paving is used as the wearing surface, this item shall consist of a single application of asphalt material on the prepared asphalt surface, followed by spreading seal coat aggregate. The asphalt material and application rates shall meet the requirements of the appropriate sections of the latest addition of MPWSS. The aggregate shall meet the gradation as set forth in Table B-1 and shall be spread per the rate of the latest addition of MPWSS.
- 3.2 Asphalt Paving.** This consists of hot plant mix asphalt concrete consisting of mineral aggregate and asphalt material mixed at a central hot plant. The mineral aggregate and asphalt material shall meet the requirements of the appropriate sections of the latest addition of MPWSS.
- 3.3 Crushed Top Surfacing.** This consists of crushed gravel, stone or other similar material consisting of hard, durable particles of fragments of stone, free of excess of flat, elongated, soft or disintegrated pieces, dirt or other deleterious matter. This is the surface course on gravel roads and streets. The material shall meet the gradation as set forth in Table B-2.
- 3.4 Crushed Base Course.** This consists of crushed gravel, stone or other similar material consisting of hard, durable particles of fragments of stone, free of excess of flat, elongated, soft or disintegrated pieces, dirt or other deleterious matter. This is the layer immediately below either a crushed top surfacing or the asphalt paving. The material shall meet the gradation as set forth in Table B-3.
- 3.5 Select Base Course.** This consists of crushed or non-crushed sub-base material of hard, durable stone, gravel or other similar materials mixed or blended with sand, stone dust, or other binding or filler materials produced from sources that provide a uniform mixture. The material shall meet the gradation as set forth in Table B-4.

TABLE A: COUNTY ROAD DESIGN CRITERIA

	Terrain	Major Collector	Minor Collector	Local Road Medium to High Density	Local Road Low Density
Design Speed (MPH)	Level	55	50	30	40
	Rolling	45	40	25	30
	Mountainous	45	30	20	20
Curvature - Minimum at Centerline (feet)	Level	575	575	250	250
	Rolling	440	440	175	175
	Mountainous	330	300	110	110
Minimum Stopping Sight Distance (feet)	Level	per AASHTO	425	200	200
	Rolling	"	305	150	150
	Mountainous	"	200	110	110
Maximum Grade	Level	per AASHTO	6%	6%	6%
	Rolling	"	8%	9%	9%
	Mountainous	"	10%	11%	11%
Length of Maximum Grade (feet)		per AASHTO	per AASHTO	per AASHTO	per AASHTO
Minimum Grade		0.5%	0.5%	0.5%	1%
Superelevation		per AASHTO	per AASHTO	N/A	N/A
Minimum Intersection Spacing (feet)		500	275	100	150
Driveway Spacing (feet)		45	45	40	40
Maximum Length of Cul-de-Sac (feet)		Not Allowed	Not Allowed	1500	1500
Minimum Radius of Cul-de-Sac (feet)		Not Allowed	Not Allowed	40	40
Sight Distance Triangle (feet)	Level	300	255	120	170
	Rolling	210	170	95	120
	Mountainous	210	120	80	80
Minimum Right of Way Width (feet)		100	80	50	50
Vertical Clearance (feet)		16.5	16.5	14.5	14.5
Intersection Curb Return Radii (feet)		25	25	15	15
Minimum Sidewalk Width (feet)		5	5	5	5
Sidewalk Offset From Back of Curb (feet)		5-10	5-10	5	N/A
Bike Lane Width (feet)		4-8	4-8	N/A	N/A
Minimum Culvert Diameter (inches)		18	15	15	15
Minimum Culvert Cover (feet)		Supplier's Recommendation	Supplier's Recommendation	Supplier's Recommendation	Supplier's Recommendation
Minimum Culvert Grade		0.5%	0.5%	0.5%	0.5%
Culvert Material		Support HS-20 Loading	Support HS-20 Loading	Support HS-20 Loading	Support HS-20 Loading

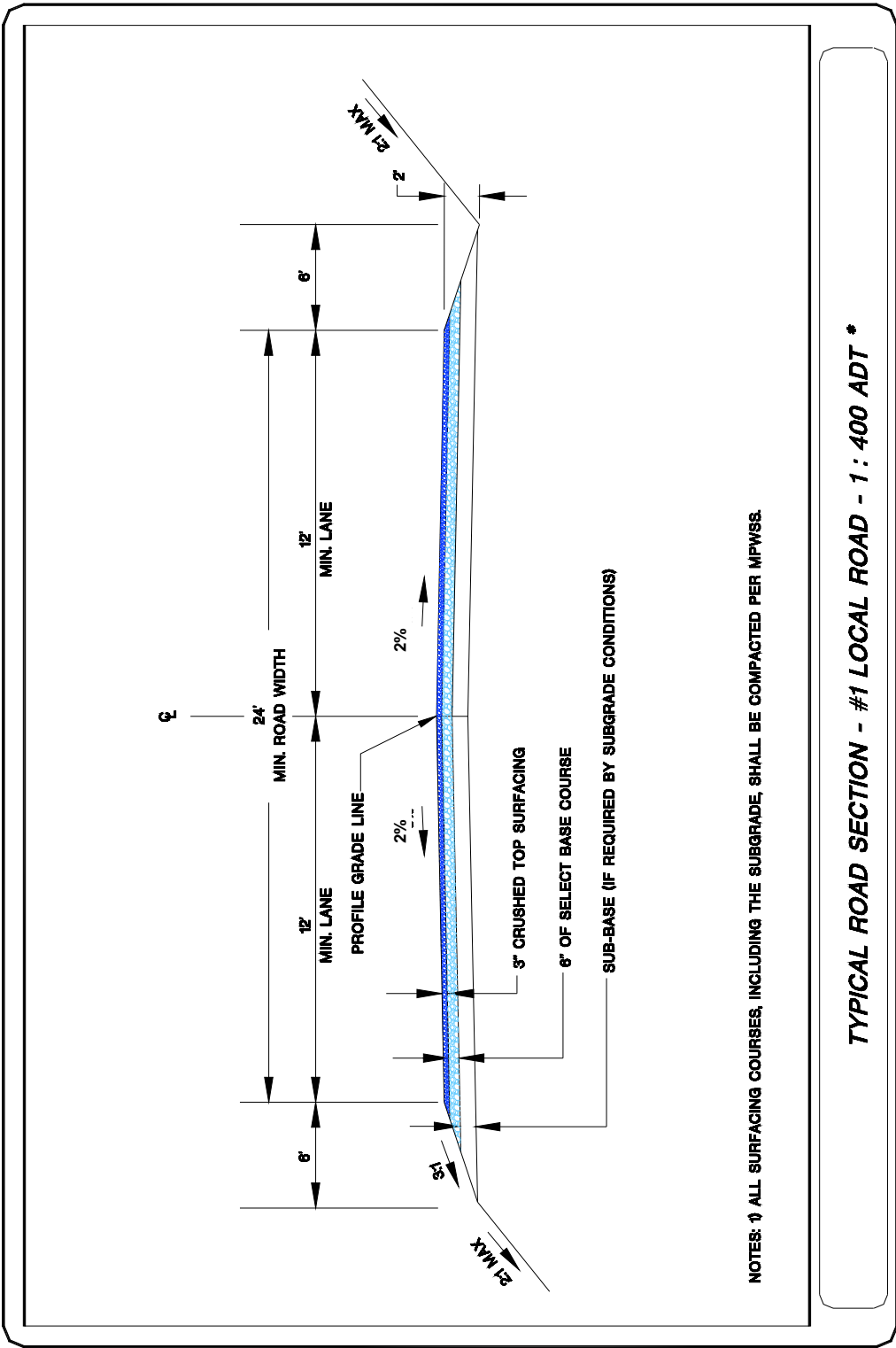

NOTES: 1) ALL SURFACING COURSES, INCLUDING THE SUBGRADE, SHALL BE COMPACTED PER MIPWSS.

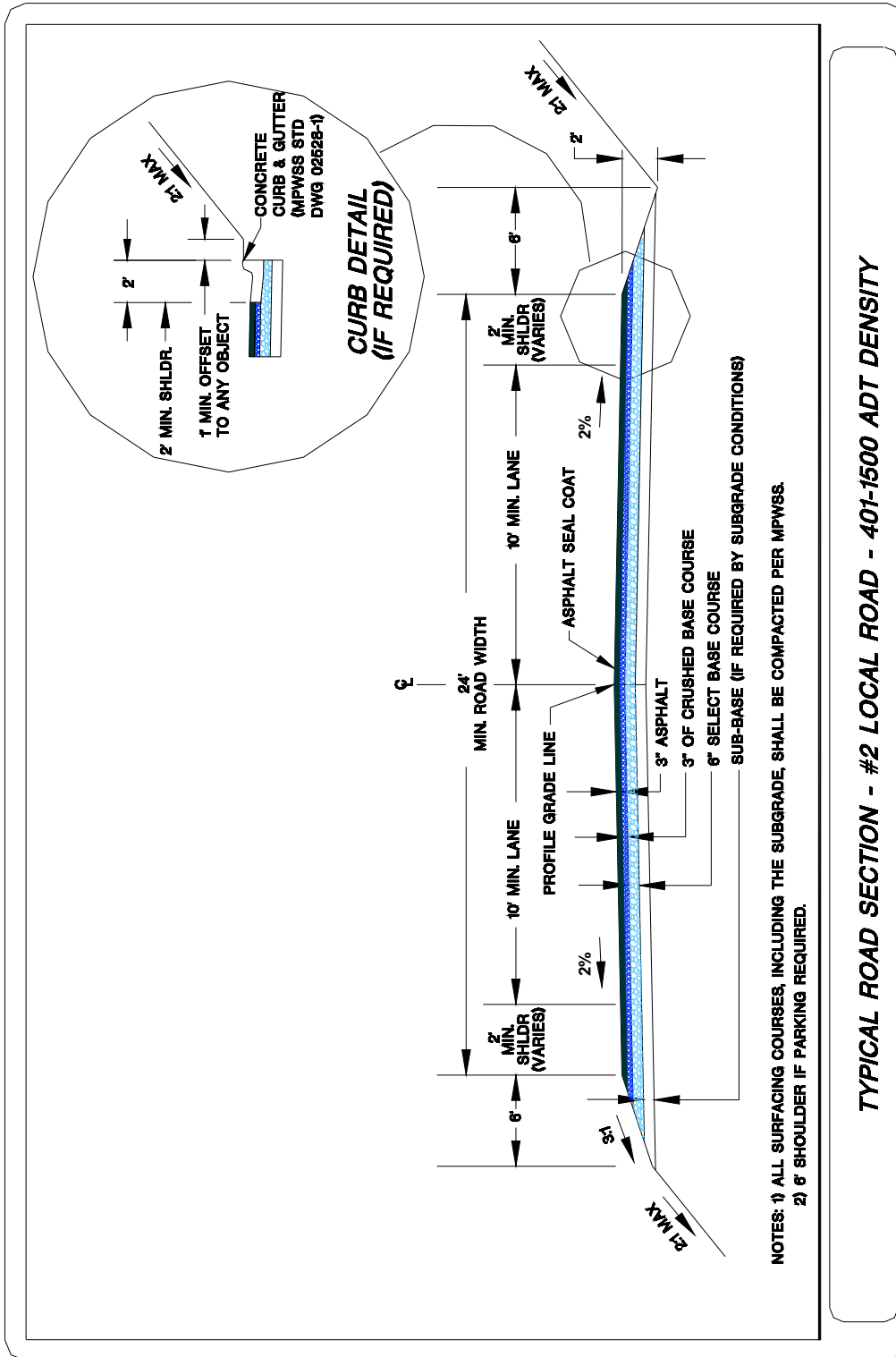

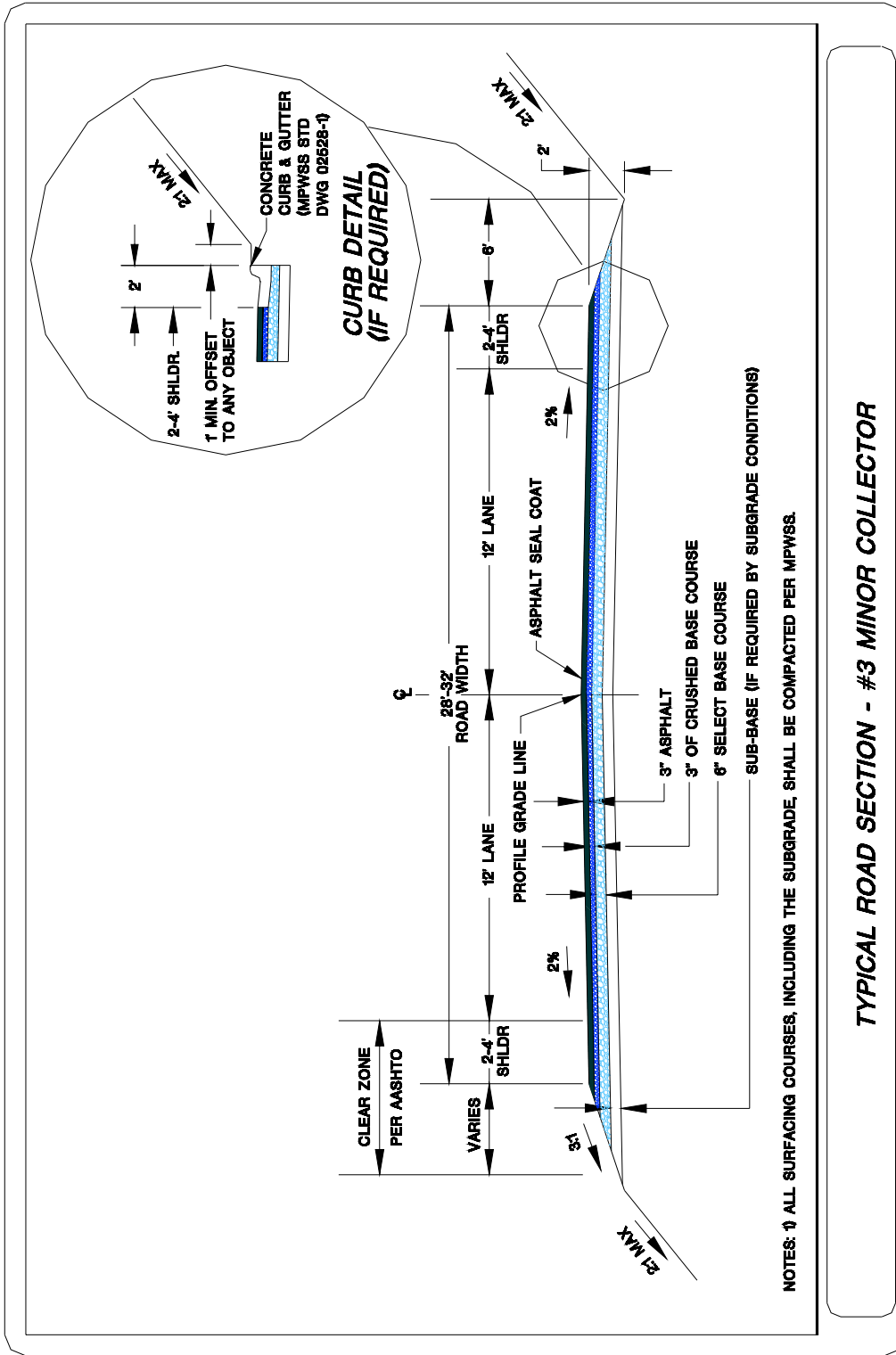

TYPICAL ROAD SECTION - #3 MINOR COLLECTOR

FIGURE 3

ACCEPTABLE TURNAROUNDS

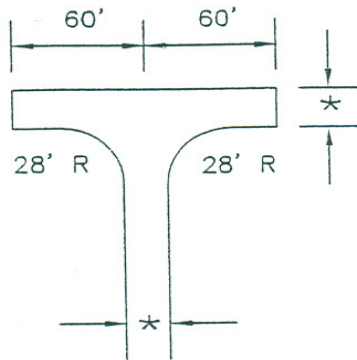

120' HAMMERHEAD

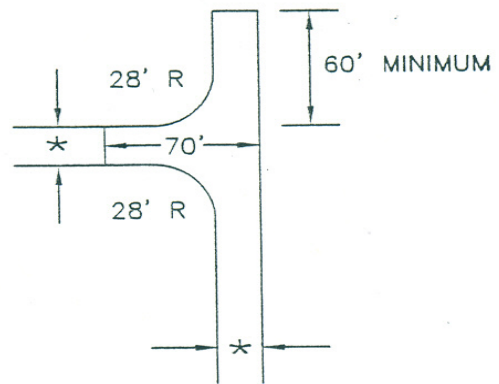

ACCEPTABLE ALTERNATIVE TO 120' HAMMERHEAD

ALL STREET DIMENSIONS ARE BASED ON CITY STREET STANDARDS AND ARE FROM FACE OF CURB.

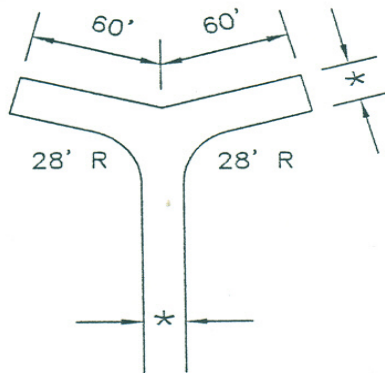

ACCEPTABLE ALTERNATIVE TO 120' HAMMERHEAD

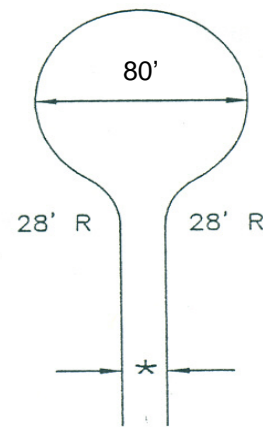

80' CUL-DE-SAC

TURNAROUNDS ARE BASED ON THE INTERNATIONAL FIRE CODE INSTITUTE APPLICATION MANUAL (1995 E

TABLE B-1
SPECIFICATION FOR CHIPS - ASPHALT SEAL COAT MATERIAL
 3/8" Asphalt Seal Coat Aggregate

TABLE OF GRADATIONS	
Percentage by Weight Passing Square Mesh Sieves (Montana Test Method MT-202)	
Sieve Size	Grade 2
1/2" sieve	100%
3/8" sieve	85-100%
#4 sieve	10-30%
#10 sieve	0-10%
#40 sieve	0-2%

- * The material from which aggregate is to be produced shall have a wear factor not to exceed 50 percent at 500 revolutions, as determined by MT-209. The abrasion test shall be run using a 5000-gram sample charge material between 3/8 inch and #4 sieves and an abrasive charge of eight balls.
- * At least 50 percent by weight of the aggregate retained on the #4 sieve shall have at least one mechanically fractured face.

TABLE B-2
SPECIFICATION FOR CRUSHED TOP SURFACING

TABLE OF GRADATIONS	
Sieve Size	Grade 2
1" sieve	
3/4" sieve	100%
1/2" sieve	
No. 4 sieve	40-80%
No. 10 sieve	25-60%
No. 200 sieve	8-20%

Meet the following requirements for crushed top surfacing, including added binder or blending material:

- * Dust Ratio: the portion passing the No. 200 sieve cannot exceed two-thirds of the portion passing the No. 40 sieve.
- * The maximum liquid limit and plasticity index for the material passing the No. 40 sieve must not exceed 35, while the plasticity index may vary from 3 to 10.
- * A wear factor not exceeding 50% at 500 revolutions.

At least 20 percent by weight of the aggregate retained on the No. 4 sieve must have on fractured face.

TABLE B-3**SPECIFICATION FOR CRUSHED BASE COURSE**

TABLE OF GRADATIONS			
Percentages by weight passing square mesh sieve			
Passing	1 ½" Minus	1" Minus	¾" Minus
2" sieve	--		
1 ½" sieve	100		
1" sieve	--	100	
¾" sieve	--	--	100
½" sieve	--	--	--
No. 4 sieve	25-60	40-70	40-70
No. 10 sieve	--	25-55	25-55
No. 200 sieve (not more than)	0-8	2-10	2-10

- * A tolerance of 5 percent, by weight, up to the next above-specified gradation (2 ½" for 2" max.) is allowed. The produced material passing the maximum screen opening and retained on the No. 4 sieve shall be reasonably well graded in its grading between those limits within 5 percent.
- * Suitability of the aggregate for its particular use is determined by the final gradation required for grading, as established by the Design Engineer, within the limits allowed in the table for the particular grading specified.
- * That portion of the fine aggregate passing the No. 200 sieve must be less than 60 percent of that portion passing the No. 40 sieve.
- * The liquid limit for that portion of the fine aggregate passing a No. 40 sieve cannot exceed 25, nor the plasticity index exceed 6, as determined by AASHTO T89 and T90.

TABLE B-4
SPECIFICATION FOR SELECT SUB-BASE COURSE

TABLE OF GRADATIONS					
Percentages by weight passing square mesh sieve					
Passing	4" Minus	3" Minus	2 ½" Minus	2" Minus	1 ½" Minus
4" sieve	100%				
3" sieve	--	100%			
2 ½" sieve	--	--	100%		
2" sieve	--	--	--	100%	
1 ½" sieve	--	--	--	--	100%
No. 4 sieve	25-60%	25-60%	25-60%	25-60%	25-60%
No. 200 sieve (not more than)	2-12%	2-12%	2-12%	2-12%	2-12%

- * A tolerance of 5 percent, by weight, up to the next above-specified gradation (2 ½” for 2” max.) is allowed. The produced material passing the maximum screen opening and retained on the No. 4 sieve shall be reasonably well graded in its grading between those limits within 5 percent.
- * Suitability of the aggregate for its particular use is determined by the final gradation required for grading, as established by the Engineer, within the limits allowed in the table for the particular grading specified.
- * The liquid limit for that portion of the fine aggregate passing a No. 40 sieve cannot exceed 25, nor the plasticity index exceed 6, as determined by AASHTO T89 and T90.

3.2 Intersections. Intersections shall be designed to meet the standards provided in Table A, Section 2-Design Controls and Criteria of these standards. The following additional items shall also be incorporated into design and construction.

- 3.2.1** Roads shall be laid out so as to intersect at an angle as near to a right angle (ninety degree angle) as practicable, but in no case less than 60 degrees for a local road intersection and no less than 75 degrees for a collector road intersection.
- 3.2.2** Intersections shall have a minimum corner radius of 15 feet along the right-of-way lines of local roads and a minimum corner radius of 25 feet at the right-of-way line at the intersection of collector or arterial roads, unless road improvements require a greater radius.
- 3.2.3** On collector and arterial roads, the dedication of right-of-way on corners shall include the chord of the radius. The County will accept an easement for this chord instead of dedication of right-of-way.
- 3.2.4** Opposing intersection of major collector roads and /or arterial roads shall either be aligned or will be separated by the minimum distance specified in Table A.
- 3.2.5** No more than two streets may intersect at one point.
- 3.2.6** Intersection design shall provide acceptable visibility for traffic safety.
- 3.2.7** Hilltop and swale intersections are discouraged and will not be allowed where adequate sight distance (per Table A) cannot be assured.
- 3.2.8** The approaching roadway shall not have a grade exceeding 3% for 50’ from the edge of the through roadway, or for 20’ outside of the through roadways right-of-way line, whichever is a lesser distance.

3.3 Dead End Roads. All dead end roads shall be provided with cul-de-sac or other approved turn-a-round area. The cul-de-sacs shall be limited to a length and radius as shown in Table A. See Figure 5 for illustrations of acceptable hammerhead Ts and cul-de-sacs.

3.4 Turnouts. A widening in a travel way of sufficient length and width to allow vehicles to pass one another. All turnouts shall be constructed of the same material as the roadway/driveway that it serves. Turnouts shall be 50 feet long and be of sufficient width that when the turnout and the road surface are added together that a total width of 20 feet is provided.

3.5 Driveways. The following items shall also be incorporated into design and construction.

- 3.5.1** All driveway approaches shall conform to the Road Approach Permit Requirements of the County Public Works Department. On paved roads the driveway approaches should be paved for 15' from the shoulder of the road and local road approaches should be paved for 30' from the shoulder of the road.
- 3.5.2** Access on horizontal curves shall only be allowed if sight distance for the design speed of the roadway can be achieved.
- 3.5.3** Driveway approaches shall have a minimum corner radius of 10 feet
- 3.5.4** Driveway turns shall have a turning radius no less than 30 feet.
- 3.5.5** Driveway approaches shall be designed so that drainage from the driveway does not drain onto the main roadway.
- 3.5.6** All driveways, including driveway bridges, shall be designed and constructed with an all-weather surface or posted that they are deficient.
- 3.5.7** As approved by the fire protection authority having jurisdiction (FPAHJ), a driveway or other means of emergency vehicle access shall be required when any point of the building is more than 150 ft (45.75 meters) from a roadway.
- 3.5.8** Driveways, including bridges and cattle guards, shall be a minimum of 12 ft (3.66 m) in width and have a vertical clearance of at least 14.5 ft (4.42 meters) over its full width.
- 3.5.9** Driveway bridges and cattle guards need to meet HS20 load rating standards.
- 3.5.10** All driveway gates shall be located a minimum of 30 ft (9.2 m) from the public right-of-way and shall not open outward. Gate openings shall provide a clear opening of not less than 12 feet.
- 3.5.11** Fire department personnel shall have ready access to a conforming locking mechanism, approved by the Fire Protection Authority Having Jurisdiction (FPAHJ), on any gate restricting access on a driveway.
- 3.5.12** Driveway vehicular easements and rights-of-way shall be a minimum of 20 feet wide to accommodate the traveled way, vegetation modification, and other local requirements.
- 3.5.13** Driveway grades shall be no greater than 12 percent, except as permitted by the FPAHJ.
- 3.5.14** Every dead-end driveway more than 300 ft (91.44 m) in length shall be provided with a turnaround at the terminus having a minimum radius of 50 ft (15.24 m) to the center line OR a "hammerhead-T" turnaround to provide emergency vehicles with a three-point turnaround ability.

4. Road Certification. Certification that new roads are constructed to County Road Standards shall be provided by the inspecting engineer, with concurrence from the County Public Works Department, after periodic inspections. Upon completion of the inspection, the inspecting engineer shall file with the Board of County Commissioners a statement either certifying that the improvements have been completed in the required manner or listing the defect in those improvements.

5. **Road Maintenance Policy.** Broadwater County will accept no new roadways for maintenance.
 - 5.1 **Rural Improvement District.** Roads constructed after approval of these Standards will only be maintained by a Rural Improvement District (RID). The RID shall be created concurrently with subdivision approval.
 - 5.2 **Trails.** Maintenance of trails, non-motorized paths and bicycle paths will not be provided by Broadwater County without written approval and development of a separate maintenance funding mechanism.
6. **Signs.** All road signs must be designed, constructed, and located according to the standards in the most current version of the Manual on Uniform Traffic Control Devices (MUTCD) published by the Federal Highway Administration. Signs identifying pertinent information such as “dead-end road,” “bridge out,” and so forth shall be appropriately located as designated by the MUTCD.
7. **Road Naming and Addressing Standards.** These shall follow the conventions laid out in Appendix H of this document.
8. **Bridges and Cattleguards.** On county roads, bridges and cattleguards shall be constructed of non-combustible materials.
9. **Easements of Rights of Ways.** Vehicular easements and rights-of-way shall be of sufficient width to accommodate the traveled way, vegetation modification, and other requirements. Where necessary, easements shall attempt to obtain from adjacent property owners to operate emergency vehicles